

ABSOLDUTE MAXIMUM RATING

- | | |
|--|-------------------------|
| 1. Operating Temperature Range | +0°C ~ +50°C |
| 2. Storage Temperature Range | -20°C ~ +80°C |
| 3. Supply Voltage | +5.5V |
| 4. Input Current (L1 ↔ L2) | 120mA max. (Ta=25± 2°C) |
| 5. Isolation Voltage (Primary / secondary) | 4KVAC/1min.(Ta=25± 2°C) |
| Leakage Current | : 1mA |
| Primary | : L1,L2 |
| Secondary | : GND,CHK,O2,O1,VCC |

ELECTRICAL CHARACTERISTICS

- | | |
|----------------------------------|---------------------------------|
| 1. Input DC Resistance | 1Ω min.~ 3Ω max. |
| 2. Input inductance (@1V,1kHz) | 0.2mH min. ~ 0.5mHmax. |
| 3. Current Consumption | 10mA typ. |
| 4. O1,O2 Working Characteristics | (Vcc=5± 5%V,Ta=0~50°C,B=0Gauss) |

After L1,L2 Apply ± 120mA :

Input Current (L1 ↔ L2)	OUPUT1		OUPUT2	
	MIN.	MAX.	MIN.	MAX.
L1=>L2 ≥ 10.5mA		0.8V	3.5V	
L1 ↔ L2 < 4.5mA	3.5V		3.5V	
L1<=L2 ≥ 10.5mA	3.5V			0.8V

UNLESS OTHERWISE SPECIFIED

TOLERANCES ON :

X = ±

X.X = ±

X.XX = ±

ANGLES ± HOLE DIA. ±

DRAWN BY :

DESIGNED BY :

CHECKED BY :

APPROVED BY :

SCALE : X UNIT : X

HYPRO ENTERPRISE CO., LTD.

THIS DRAWINGS AND SPECIFICATIONS ARE THE PROPERTY OF HYPRO ENTERPRISE CO., LTD.
AND SHALL NOT BE REPRODUCED OR USED AS THE BASIS FOR THE MANUFACTURE
OR SALE OF APPARATUS OR DEVICES WITHOUT PERMISSION

TITLE : ENGINEERING SPEC. FOR MA91000009

DOCUMENT
NO.

92101A00000

PAGE
REV.

0

O1,O2 TEST

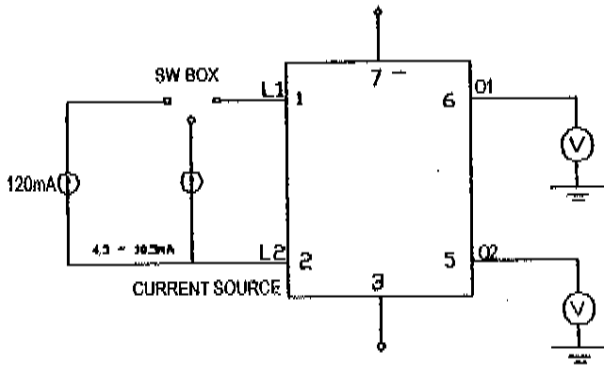

After L1,L2 Apply $\pm 120\text{mA}$:

Input Current L1 \leftrightarrow L2 :

- (1) L1 \Rightarrow L2 $\geq 10.5\text{mA}$, Test O1,O2
- (2) L1 \leftrightarrow L2 $< 4.5\text{mA}$, Test O1,O2
- (3) L1 \Leftarrow L2 $\geq 10.5\text{mA}$, Test O1,O2

FUNCTION BLOCK DIAGRAM

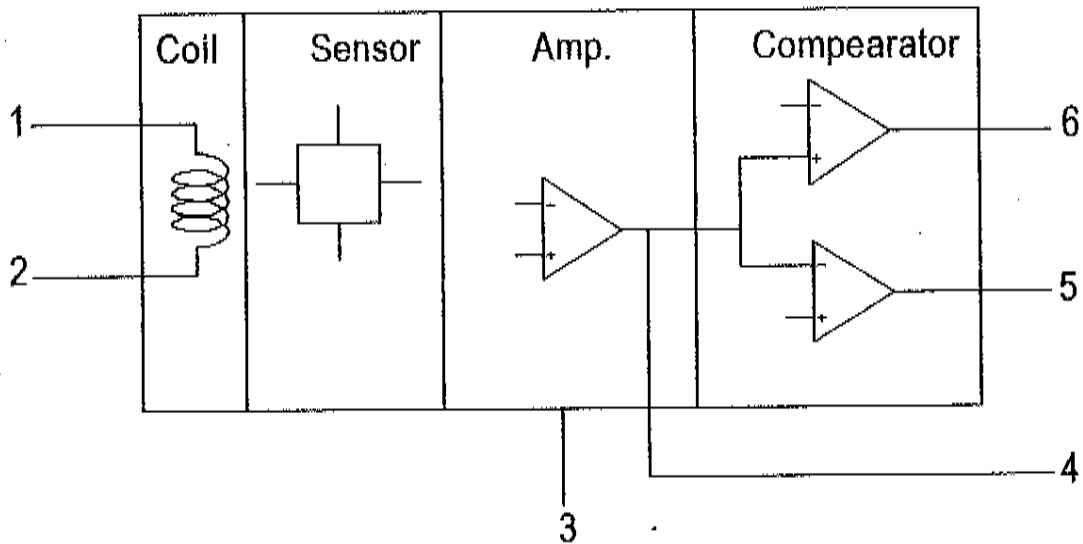

- 1. COIL INPUT +
- 2. COIL INPUT -
- 3. GROUND
- 4. CHECK
- 5. OUTPUT 2
- 6. OUTPUT 1
- 7. Vcc

UNLESS OTHERWISE SPECIFIED TOLERANCES ON : X = \pm X.X = \pm X.XX = \pm ANGLES \pm HOLE DIA. \pm	DRAWN BY :		<i>HYPRO ENTERPRISE CO., LTD.</i>
	DESIGNED BY :		
	CHECKED BY :		
	APPROVED BY :		
	SCALE : X	UNIT : X	THIS DRAWINGS AND SPECIFICATIONS ARE THE PROPERTY OF HYPRO ENTERPRISE CO., LTD. AND SHALL NOT BE REPRODUCED OR USED AS THE BASIS FOR THE MANUFACTURE OR SALE OF APPARATUS OR DEVICES WITHOUT PERMISSION
TITLE : ENGINEERING SPEC. FOR MA91000009		DOCUMENT NO.	92101A00000 PAGE REV. 0

OUTLINE DIMENSION

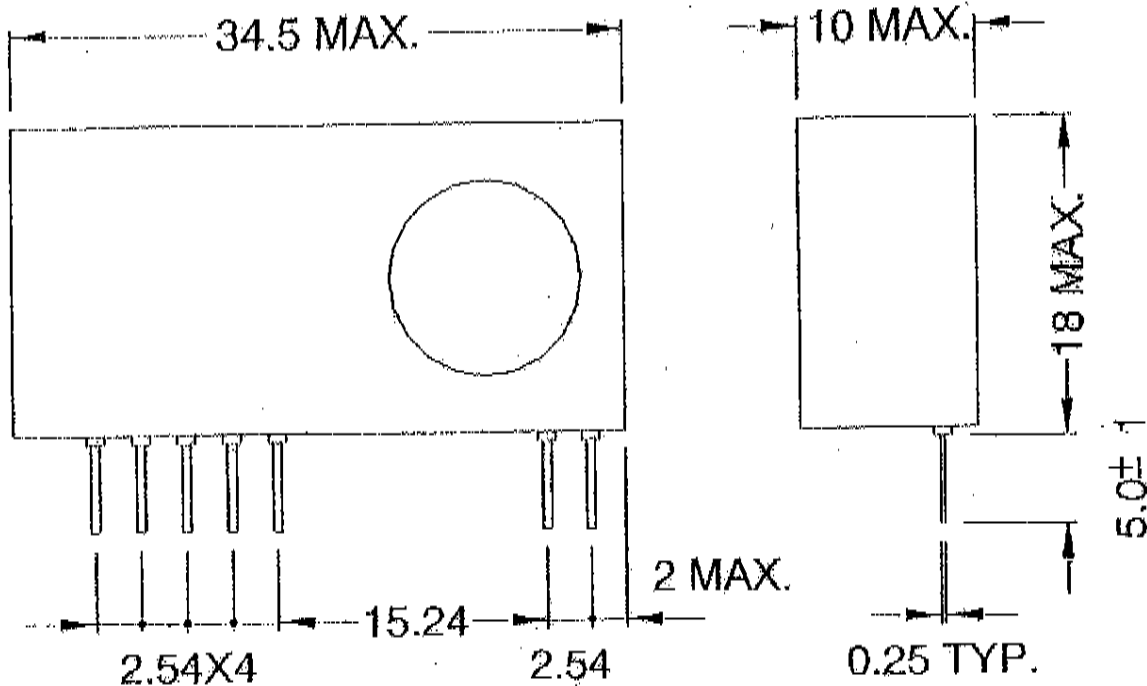

MARKING & PIN ASSIGNMENT

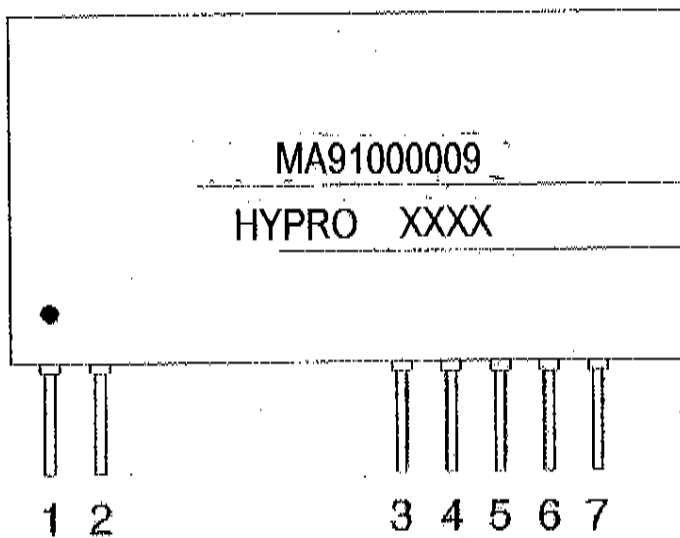

- 1.Coil input +
 - 2.Coil input -
 - 3.Ground
 - 4.Check
 - 5.Output 2
 - 6.Output 1
 - 7.Vcc
- Model No.
Date Code

UNLESS OTHERWISE SPECIFIED TOLERANCES ON : X = ± X.X = ± X.XX = ± ANGLES ± HOLE DIA. ±	DRAWN BY :	HYPRO ENTERPRISE CO., LTD.	
	DESIGNED BY :		
	CHECKED BY :		
	APPROVED BY :		
	SCALE : X	UNIT : X	THIS DRAWINGS AND SPECIFICATIONS ARE THE PROPERTY OF HYPRO ENTERPRISE CO., LTD. AND SHALL NOT BE REPRODUCED OR USED AS THE BASIS FOR THE MANUFACTURE OR SALE OF APPARATUS OR DEVICES WITHOUT PERMISSION
TITLE : ENGINEERING SPEC. FOR MA91000009	DOCUMENT NO.	92101A00000	PAGE REV. 0

Mechanical Test

1. Soldering Heat Resistance

Immerse the parts up to 2 ~ 2.5 mm from the bottom in a solder bath of $260 \pm 5^\circ\text{C}$ for 10 ± 1 sec
There should be no damage in appearance. Measure the parts after 2 hours and the initial values under item "Electrical Characteristics" should be met.

2. Lead Strength

2.1 Pull Strength

Fasten the parts and pull the lead gradually in a radial direction with 0.5Kg load, keep the load for 5 sec.

The parts should not be damaged thereafter.

2.2 Bend Strength

Fasten the parts and apply 0.25Kg gradually in radial direction and bend the lead 90° , straighten the lead, apply 0.25Kg again to the lead and bend it in an opposite direction at 90° and straighten it back again, The lead should not be damaged thereafter.

3. Solderability of Leads

The lead terminal will be immersed in the isopropyl alcohol with rosin solution (the concentration of rosin will be allowed 10% ~ 35% and normally approx. 25% will be used without any specific requirement.)

Then the lead terminal leaving 1 ~ 1.5mm from the edge of HIC will be immersed in the solder solution at the temperature of $230 \pm 5^\circ\text{C}$ for 5 ± 1 seconds, and pulled up completely, The solder will adhere to over 90% of the lead terminal.

Environmental Test

1. Humidity Test

Part are subjected to a temperature $40 \pm 2^\circ\text{C}$ with 90% ~ 95% RH for 100 hours.

Return the parts to room temperature (25°C) for 4 hours and measure. The initial values under item "Electrical Characteristics" should be met.

2. Thermal Cycle Test

Parts are subjected to 5 cycles of the following :

STEP	CONDITION	DURATION
1	$-25 \pm 3^\circ\text{C}$	30minutes
2	Room Temp	10 ~ 15 minutes
3	$70 \pm 2^\circ\text{C}$	30 minutes
4	Room Temp	10 ~ 15 minutes

The parts are placed in room temperature (25°C) for 2 hours and are measured.

Values listed "Electrical Characteristics" should be met.

UNLESS OTHERWISE SPECIFIED TOLERANCES ON : X = \pm X.X = \pm X.XX = \pm ANGLES \pm HOLE DIA. \pm	DRAWN BY :		<i>HYPRO ENTERPRISE CO., LTD.</i>
	DESIGNED BY :		
	CHECKED BY :		
	APPROVED BY :		
	SCALE : X	UNIT : X	THIS DRAWINGS AND SPECIFICATIONS ARE THE PROPERTY OF HYPRO ENTERPRISE CO., LTD. AND SHALL NOT BE REPRODUCED OR USED AS THE BASIS FOR THE MANUFACTURE OR SALE OF APPARATUS OR DEVICES WITHOUT PERMISSION
TITLE : ENGINEERING SPEC. FOR MA91000009	DOCUMENT NO.	92101A00000	PAGE REV. 0

Notice

1. Soldering

Please solder the products with rosin flu. Do not use acid or alkaline flux, because they may damage metallic parts and glass parts and may cause defective or low quality products.

2. Cleaning

If you use aqueous, semi-aqueous cleaning or no-cleaning type flu and you don't clean our products, you must confirm the reliability of the products fully in advance.

3. Storage

3.1 please store the products in room where the humidity/humidity is stable and direct sunlight cannot come in. Avoid damp heated places or such places where there are large humidity changes, because water may condense on the products, the characteristics may be reduced in quality, and/or be degraded under the solder ability. Please store the products under the following conditions :

"Recommended storage condition :

Humidity	5 ~ 35°C
Humidity	40 ~ 70%RH"

And please use the product within 6 months after delivery. If you store the products for a long time (more than 1 year), use caution because the products may be degraded in the solder ability any/or rusty. Please confirm solder ability and characteristics for the products regularly.

3.2 Please do not store the products in the places such as : in a dusty place, in a place exposed directly to sea

Breeze, in an atmosphere containing corrosive gas (Cl₂,NH₃,SO₂,NOX so on).

4. Operational Environment and Operational Conditions

4.1 Operational Environment

The products are not waterproof, chemical-proof or rust-proof. In order to prevent leakage of electricity and abnormal humidity increase of the products, do not use the products under the following circumstances :

- (1) in an atmosphere containing corrosive gas
- (2) in a dusty place
- (3) in a place exposed to direct sunlight
- (4) in such a place where splashes or in such a humid place where water condense
- (5) in any other places similar to the above (1) through (5)

UNLESS OTHERWISE SPECIFIED TOLERANCES ON : X = ± X.X = ± X.XX = ± ANGLES ± HOLE DIA. ±	DRAWN BY :		<i>HYPRO ENTERPRISE CO., LTD.</i>		
	DESIGNED BY :				
	CHECKED BY :				
	APPROVED BY :				
SCALE : X		UNIT : X		THIS DRAWING AND SPECIFICATIONS ARE THE PROPERTY OF HYPRO ENTERPRISE CO., LTD. AND SHALL NOT BE REPRODUCED OR USED AS THE BASIS FOR THE MANUFACTURE OR SALE OF APPARATUS OR DEVICES WITHOUT PERMISSION	
TITLE : ENGINEERING SPEC. FOR MA91000009			DOCUMENT NO.	92101A00000	PAGE REV. 0

4.2 Operational Conditions

Please use the products within specified values (power supply, humidity, input & output condition, and so on), If you use the products over the specified caules, it may break products, reduce the quality, and even if the products can endure the condition for short time, It may cause degradation of reliability

4.3 Note prior to use

If you apply high static electricity, over rated voltage or reverse voltage to three products, it may cause defects in the products or degrade the reliability. Please avoid the following item :

- (1) over rating power apply, reverse power supply or not-enough connection of 0Vdc
- (2) electrostatic discharge by production line and/or operator
- (3) electrified product by electrostatic induction

Do not give an excessive mechanical shock. If you drop the products on the floor, etc. ,it may transform outline or characteristics of products. Do not five a strong shock such as a drop in handling.

5. Transportation

If you transport the products, please pack them so that package will not be damaged by mechanical vibration or mechanical shock, and please educate and guide a carrier to percent rough handling. If you transport the products to overseas (in particular, by sea), it is expected that the transportation environment will be the worst, so please pack the products, in the package designed on the consideration of mechanical strength, vibration-resistant and humidity-resistant.

UNLESS OTHERWISE SPECIFIED TOLERANCES ON : X = ± X.X = ± X.XX = ± ANGLES ± HOLE DIA. ±	DRAWN BY :		<i>HYPRO ENTERPRISE CO., LTD.</i>
	DESIGNED BY :		
	CHECKED BY :		
	APPROVED BY :		
	SCALE : X	UNIT : X	THIS DRAWINGS AND SPECIFICATIONS ARE THE PROPERTY OF HYPRO ENTERPRISE CO., LTD. AND SHALL NOT BE REPRODUCED OR USED AS THE BASIS FOR THE MANUFACTURE OR SALE OF APPARATUS OR DEVICES WITHOUT PERMISSION
TITLE : ENGINEERING SPEC. FOR MA91000009		DOCUMENT NO.	92101A00000
			PAGE REV. 0